

**DEI - Doppio effetto inox / DEI - Double acting stainless steel**

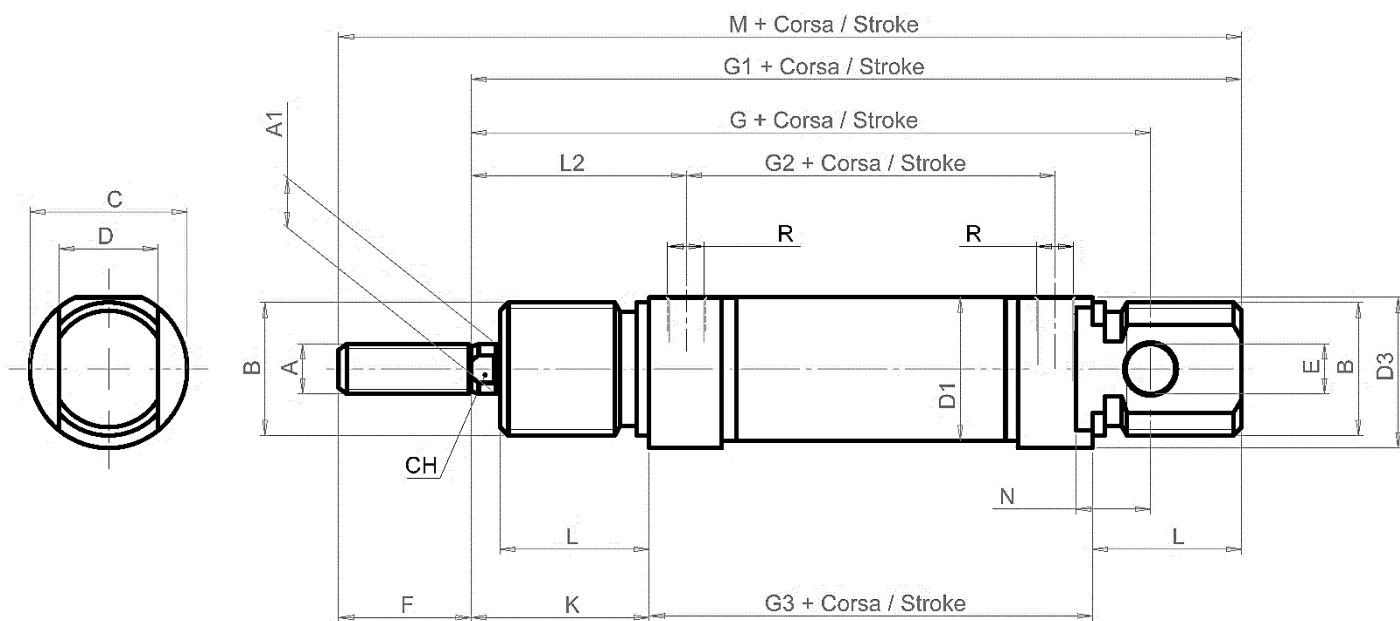

Ø mm	A	A1	B	C	D	D1	D3	E	F	G	G1	G2	G3	K	L	L2	N	CH	R	M
16	M6	6	M16 x 1,5	19	12	17,27	18	6	16	82	93	44	53	22	18	27	9	5	M5	109
20	M8	8	M22 x 1,5	27	16	21,27	25,5	8	20	95	111	51,5	67	24	20	32	12	7	1/8"	131
25	M10 x 1,5	10	M22 x 1,5	30	16	26,5	28,5	8	22	104	118	52	68	28	22	36	12	9	1/8"	140

**Corse disponibili / Available stroke**

Corsa / Stroke	Ø16	Ø20	Ø25
10	X	X	X
25	X	X	X
50	X	X	X
80	X	X	X
100	X	X	X
125	X	X	X
160	X	X	X
200	X	X	X
250	X	X	X
300	X	X	X
320	X	X	X
400	X	X	X
500	X	X	X